



COAX SERIES FX50 & FX80
User Guide

Table of Contents

English

- Introduction 1
- What's Inside? 1
- FX Series Monitors Features 1
- Front and Rear Panel Features 2
- Installation 4
- Connecting to Preamp or Computer Outputs 6
- Positioning Your FX Series Monitors 6
- Warranty 6
- Technical Specifications 7
- FX50 & FX80 Response Graphs 8

Introduction

Thank you for choosing the FX Series bi-amplified, near-field studio reference monitor. Fluid Audio is quickly becoming a recognized brand the world over for professional audio monitoring. Designing speakers for almost 30 years, the founders of Fluid Audio are also songwriters and musicians just like you and know exactly what is required for tracking and mixing great music. Now, after painstaking tuning and voicing, Fluid Audio is proud to present the FX Series of monitors.

Although the FX Series sound great playing your favorite music files or streaming, they are intended for music creation and more importantly, creating a mix that will translate to your car, your home hi-fi or any other playback system.

The reason for this is the FX Series' well-balanced frequency response - so you won't hear any frequency louder or softer than any other - and also because they image so well. What is imaging? When you listen to music, and close your eyes, can you picture where the instruments are on the "virtual 3D stage"? If you can, then you have speakers that image very well-like the FX Series monitors.

Not only do they provide a clearer view into the music you are making (or just listening to) they also overcome many of the limitations found in many other speakers. Using quality speaker drivers and employing a sophisticated DSP crossover network, they sound clear and transparent. Utilizing a Class-D amplifier ensures extremely efficient power delivery. The DIP-switches on the rear panel allow for response correction to account for different studio sizes and positions. From Pro engineers at commercial studios to home studio owners, the FX Monitors from Fluid Audio set a new, affordable standard in audio monitoring.

What's Inside?

Your FX series monitor box contains:

- One (1) FX studio monitor
- Detachable AC power cord
- This users guide
- Acoustic isolation pads

FX Series Monitors Features

Woofers

The woofer driver utilizes a low distortion magnet structure that drives a high temperature voice coil, which is mounted to a polypropylene coated, paper pulp cone. The cone is anchored to the frame with a pliant butyl rubber surround which minimizes high frequency resonant peaks that may be transmitted from the cone. Although many claim to use "space age" materials in their cones, since the 1920's, the most popular material for woofer cones has been paper pulp. Why? Not only it's great strength-to-weight ratio, but because of its excellent damping characteristics – leaving the woofer to reproduce pure tones, not the ringing resonances.

Tweeter

The tweeter is a silk dome which is driven by a neodymium magnet. What makes it unique however, is that it is mounted in the center of the woofer, with the waveguide mounted in a coaxial configuration. Not only does this make the "acoustic center" the same for both the woofer and tweeter, which drastically improves the speaker's vertical off axis response, but it also allows the speaker cabinet to be a little shorter and more compact. The tweeter provides exquisite detail while providing a very natural response. Utilizing a special damping material beneath the silk dome, resonance and audible distortion is drastically reduced. The silk dome is protected by an acoustically transparent steel mesh grille, to keep it from being damaged.

Bass-Reflex Slot Port

The slot opening at the bottom of the front of the speaker enclosure is the bass-reflex vent port. It is designed to effectively tune the speaker cabinet to a certain frequency, and maximize the bass output of the speaker. It is put on the front panel in order to fire directly at the listener, and also to allow for flexibility of placement (as a rear firing port may interfere with the wall behind it).

Enclosure and EQ DIP-switches

The enclosure design of the FX Series monitors have a very important role in shaping the overall sonic response of the speaker. Besides being made of acoustically efficient MDF material, it is also reinforced by internal bracing to ensure solid bass response. The customized front baffle uses large radii all around- which aids in minimizing acoustic diffraction. The rear amplifier panel sports EQ dip-switches, which allow you to contour the sound of the monitors depending on the environment they are being used in. Too much bass due to the speaker's proximity to the back wall? Then back that down with the Acoustic Space switches. Not enough high frequency because of a well damped room, then add some more back with the High frequency adjust switches. (Read more below).

Amplification and Crossover Network

The Class-D, bi-amplified design separately drives the low and high frequency drivers – allowing each to work independently and more efficiently. When the speakers are not being used (receiving no signal), there is an integrated standby function that powers down the amplifier to conserve energy. Combined with a phase-optimized, DSP crossover network, the drivers blend together, resulting in a coherent soundstage across the entire audio spectrum.

Front and Rear Panel Features

Rear Panel Features

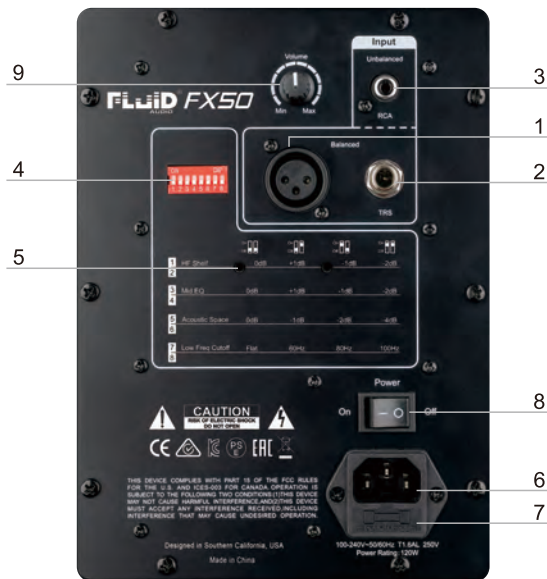

1. XLR INPUT: This jack accepts XLR input connections with either balanced or unbalanced wiring. The input wiring of an XLR connector should be as follows:

- XLR PIN 1 signal ground (shield)
- XLR PIN 2 positive (+)
- XLR PIN 3 negative (-)

2. TRS INPUT: This jack accepts 1/4" connections with either balanced or unbalanced wiring. For balanced wiring, a three-conductor TRS plug is necessary. The input wiring of a TRS connector should be as follows:

Fluid Audio FX Series Coax Reference Monitor

- TRS TIP signal positive (+)
- TRS RING signal negative (-)
- TRS SLEEVE signal ground (shield)

Unbalanced 1/4" wiring can be done with either a two- or three-conductor (TS or TRS) plug. A two-conductor (TS) plug automatically grounds the signal negative input, whereas a three-conductor (TRS) plug, wired unbalanced, provides the option of leaving the negative input open or grounded. We recommend that you ground the unused negative input (this can be done by wiring the ring and sleeve of the TRS plug together).

3. RCA INPUT: This jack accepts RCA input connections with unbalanced wiring.

4. EQ DIP-SWITCHES: The diagram below shows you how to adjust your EQ settings:

- A. HF Shelf: This decreases or increases the high frequency output depending on taste or the absorptive characteristics of the studio or room you are in. Shelf starts at 7kHz.
- B. Mid EQ: This decreases or increases the mid-range frequency output depending on taste or the absorptive characteristics of the studio or room you are in. Center frequency at 1.5kHz.
- C. Acoustic Space: Also known as boundary compensation, this reduces the low frequency bass "loading" that occurs as the speaker is placed close to a wall or corner. See below for more detail about properly adjusting the acoustic space settings.
- D. Low Freq Cutoff: This provides low frequency or bass roll-off at 12dB per octave, depending at what frequency you wish to integrate your FX monitor with a subwoofer.

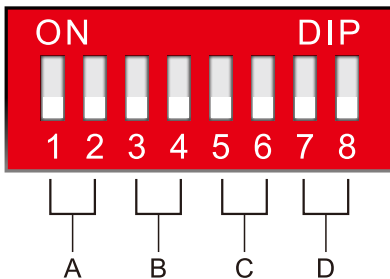
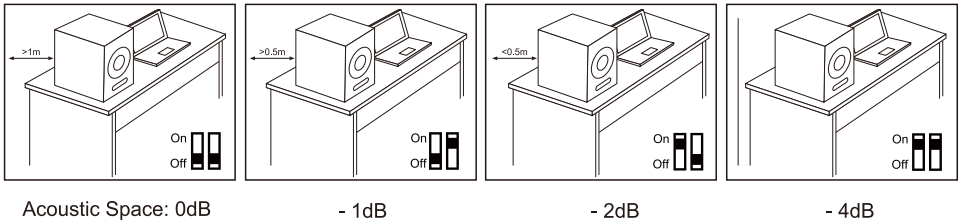

EQ DIP-SWITCHES

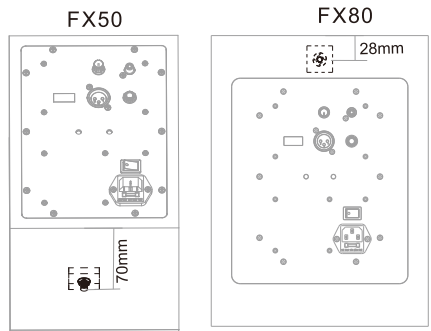

MOUNTING SCREW HOLES

5. MOUNTING SCREW HOLES: These holes will allow you to safely mount your FX monitors using the Fluid Audio approved LD systems bracket (SAT WMB 10). The safety cable can be screwed into a nut found on the bottom of the FX50 cabinet, and on the back side of the FX80. (The black vinyl covers these, so you will have to search for them).

- 6. POWER RECEPTACLE:** Accepts a detachable 3-circuit line cord in order to power the monitor. The FX Series is equipped with an international switch-mode power supply, so there is no need to set it for your local voltage or frequency.
- 7. FUSE HOLDER:** Holds the spare user replaceable main fuse.
- 8. POWER ON/OFF SWITCH:** This switch turns the monitor on and off. Make sure to power the monitor off when connecting the power cable.
- 9. VOLUME CONTROL:** The volume control allows for adjustment of the monitor's output from - to +6dB. There are several detents along the travel of the knob that will allow to match your loudness on both the L an R channels.

Front Panel Features

The front panel houses the "power on" LED indicator. When the speaker is turned on and there is signal playing, it will turn blue. If there is no signal after 45 minutes, it will turn red, which indicates that the monitor is in standby mode.

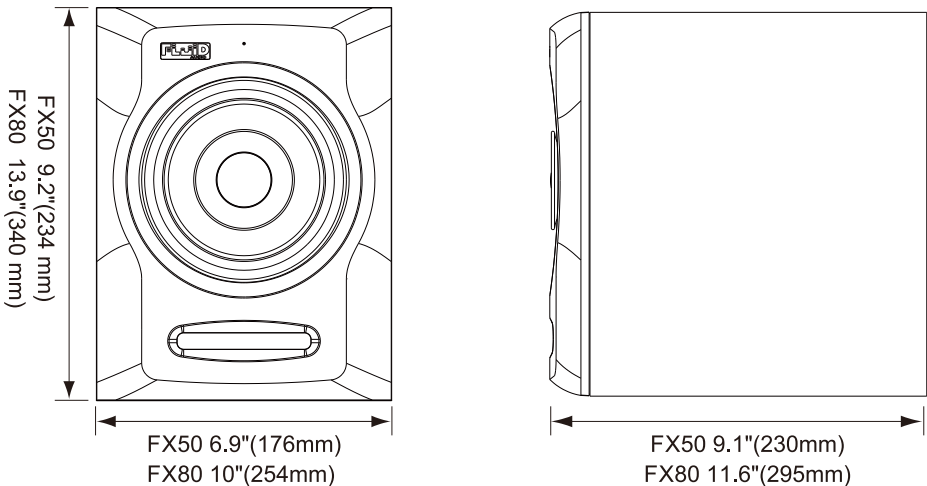

Installation

For optimal performance of your FX monitors, please read the following thoroughly and carefully prior to installation.

Precautions

Caution: Please read, heed and keep all of these instructions and warnings in this user guide.

Water: Please keep powered speakers and related devices away from water or splashing.

Handling: Please do not touch the speaker cones. The FX speakers are tightly packed, so your attention is required when taking them out of the box. To avoid possible damage to the speaker units, hold both sides of the monitor while pulling it out of the box. The speaker cones should not be touched in order to avoid damage even after they are out of the box.

Correct Power Operation: Since the FX Series monitors contain their own amplifier, they must be connected to a power outlet using the detachable AC cable provided. Do not defeat the safety purpose of the polarized or grounding-type plug. Please use the correct AC power plug for your region. (It should come with your FX speaker, but if it does not, please contact the retailer you purchased the FX speaker from).

Power cord: Protect the power cord from being walked on or pinched, particularly at plugs, receptacles, and at the point where they exit the FX Series monitor.

Connections: You can connect either an XLR balanced cable, TRS balanced/unbalanced cable or RCA unbalance cable from the input of the FX monitors to your corresponding preamp, interface or mixer outputs. We recommend that you use high-quality balanced or unbalanced cables for input connections. Also, always turn off the power of the FX monitor and turn the volume to a minimum before making the necessary connections.

Usage: All Fluid studio monitors are designed to be used on flat, counter-top surfaces. If they are to be used with a bracket for wall mounting, only the approved bracket from LD systems is to be used (see diagram above). Use only attachments and/or accessories specified by the manufacturer.

Caution: Never remove the rear panel of these powered monitors. To do so could result in electric shock. A qualified technician should perform any repair or service to the electronics.

Hearing protection: This product is capable of producing sounds at a level that could be damaging to hearing and result in permanent hearing loss over an extended period of time.

XLR Balanced Connection

Assure that the power switch of the FX Series Monitor is turned off and that the volume control is turned down to a minimum. Connect the male end of an XLR balanced cable to the balanced input of the FX monitor. (Refer to the following diagram for balanced connection).

TRS Balanced/Unbalanced Connection

Assure that the power switch of the FX Series monitor is turned to off and that the volume control is turned down to a minimum. Connect the male end of a TRS balanced or TS unbalanced cable to the TRS input of your FX monitor. (Refer to the following diagram for TRS connection).

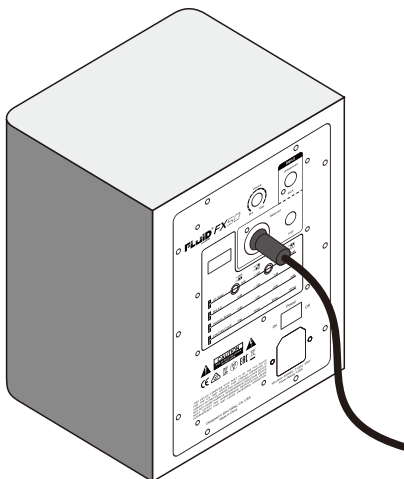

XLR Balanced Connection

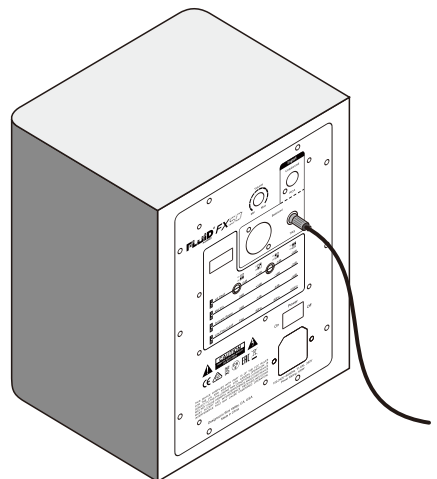

TRS Balanced Connection

Connecting to Preamp or Computer Outputs

Before connecting, make sure the output device's power has been turned off. Plug the XLR balanced or RCA cable to the corresponding output connectors of a pre amplifier.

FX Orientation and Listening Position

Placement of your speakers is one of the most important procedures in order to get the best from your listening experience. To listen with the FX's performing to their maximum capability, an appropriate listening environment and correct placement are required. Please refer to the following for correct FX placement. Whether they are placed on a table or a bookshelf, make sure that nothing is blocking the speaker drivers, and try not to surround them with things like books, etc. Like a fine wine, they need to breathe.

1. The two speakers and the listener should basically align to form a regular triangle. Refer to the diagram below.
2. Position the speakers so that the middle of the cabinet is level with your ears in a normal listening environment. As seen in the diagram below.
3. Since the FX are coaxial speakers, their performance will be virtually the same if laid on their side. However, you may want to put them on stands to get the tweeter closer to ear level.
4. If wall mounting your FX speakers using a bracket, the speakers will most likely be very close to a wall. If this is the case, you may try using the acoustic space setting

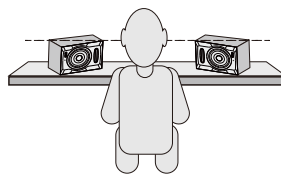
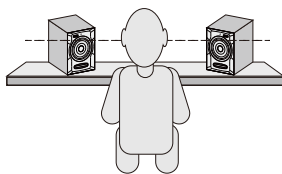
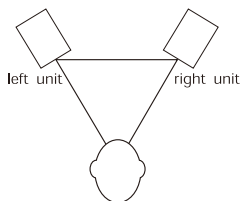

Remarks: DO NOT place any obstacles that may block the flow of air in front or between the monitors. Also remove reflective materials such as glass, mirrors or metal from the monitoring environment. PLACE THOSE MATERIALS AWAY FROM THE PATH OF THE SOUND FROM THE FX MONITORS.

Warranty

Warranty Terms

Fluid Audio warrants products to be free from defects in materials and workmanship, under normal use and provided that the product is owned by the original, registered user.

Contact your local retailer or place of purchase for terms and limitations applying to your specific product. Terms may differ depending on country of purchase

Technical Specifications

	FX50	FX80
Type:	2-Way, Coaxial Studio Monitor with Class D Amplifier	2-Way, Coaxial Studio Monitor with Class D Amplifier
LF Driver:	5" composite curved cone with high temperature voice coil and damped rubber surround	8" composite paper cone with high temperature voice coil and damped rubber surround
HF Driver:	1" natural silk dome	1.2" natural silk dome
Frequency Response:	49Hz-22kHz	35Hz-22kHz
Crossover Frequency:	2.95kHz	2.4kHz
LF Amplifier Power:	50Watts	60Watts
HF Amplifier Power:	40Watts	50Watts
S/N Ratio:	>90dB(Typical A-weighted)	>90dB(Typical A-weighted)
MAX SPL@1M:	89dB	95dB
Input Connectors:	1 × XLR balanced input connector 1 × TRS balanced input connector 1 × RCA unbalanced input connector	1 × XLR balanced input connector 1 × TRS balanced input connector 1 × RCA unbalanced input connector
Polarity:	Positive signal at + input produce outward LF cone displacement	Positive signal at + input produce outward LF cone displacement
Input Impedance:	20 k ohms balanced, 10 k ohms unbalanced	20 k ohms balanced, 10 k ohms unbalanced
Input Sensitivity:	85mV pink noise input produces 89dBA output SPL at one meter with volume control at maximum	85mV pink noise input produces 95dBA output SPL at one meter with volume control at maximum
Protection:	RF interference, output current limiting, over temperature, turn-on/off transient, subsonic filter, external mains fuse.	RF interference, output current limiting, over temperature, turn-on/off transient, subsonic filter, external mains fuse.
Indicator:	Power indicator on front panel	Power indicator on front panel
Power Requirement:	100 - 240V ~50/60Hz	100 - 240V ~50/60Hz
Cabinet:	Vinyl-laminated high acoustic efficient MDF	Vinyl-laminated high acoustic efficient MDF
Dimension:	234mm(H) × 176mm(W) × 230mm(D)	340mm(H) × 254mm(W) × 295mm(D)
Weight:	3.8kgs(without packing)	7.9kgs(without packing)

WARNING: This product contains chemicals, including lead, known to the State of California to cause cancer, and birth defects or other reproductive harm. Wash hands after handling.



©2019 Fluid Audio. All rights reserved. Product features, specifications, system requirements and availability are subject to change without notice. Fluid Audio is trademark or registered trademark of Fluid Audio in the U.S. and other countries. All other trademarks contained herein are the property of their respective owners.

FX50 & FX80 Response Graphs

FX50 ANECHOIC ON-AXIS MEASUREMENT AT 1 METER

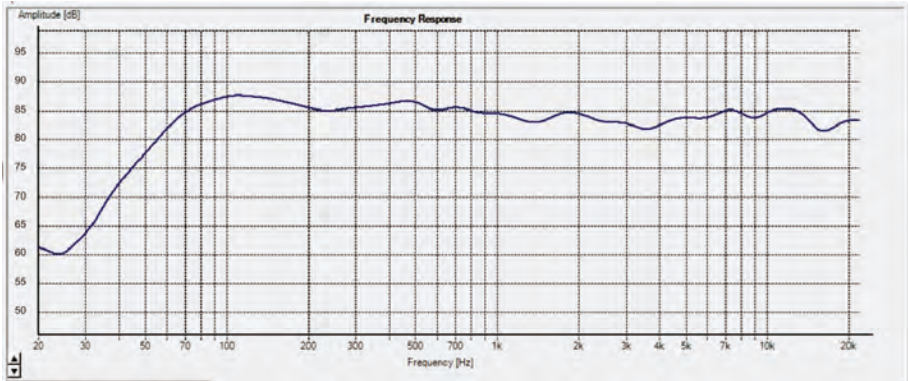

FX80 ANECHOIC ON-AXIS MEASUREMENT AT 1 METER

